

Modular Reducing Valve

03 External dimensions

DYJ-03-A, P ...

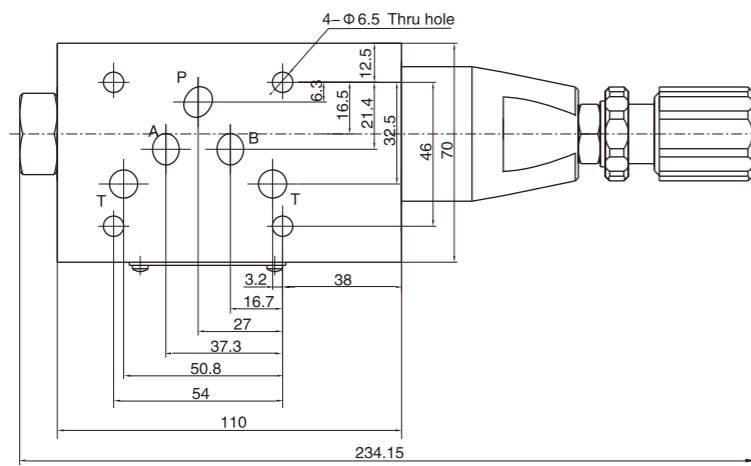
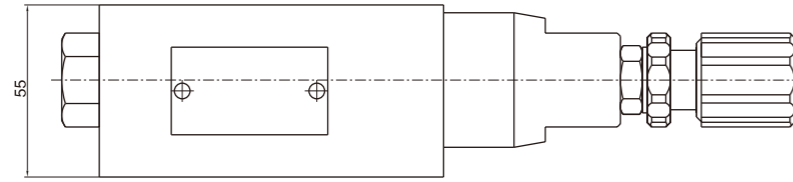

DYJ-03-B

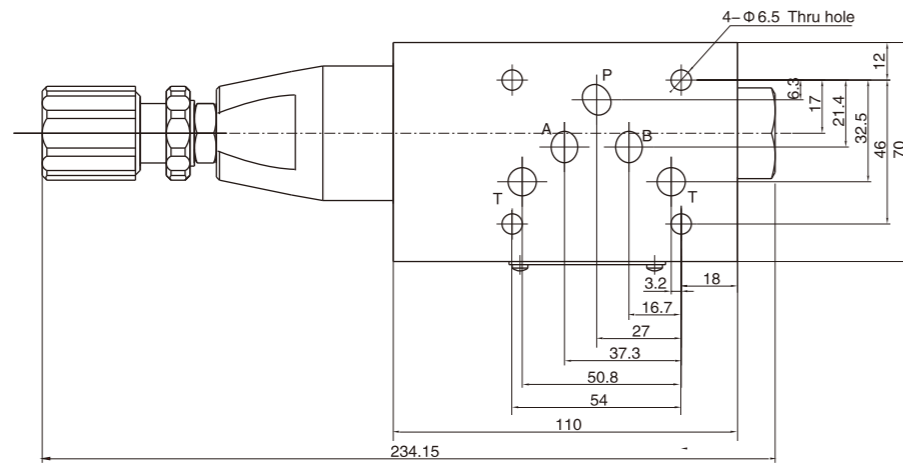
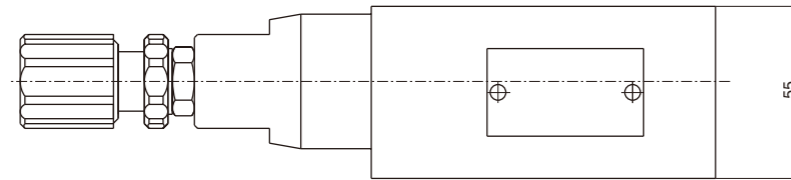

B.7.3

Modular Counter-balance Valve

Technical specification

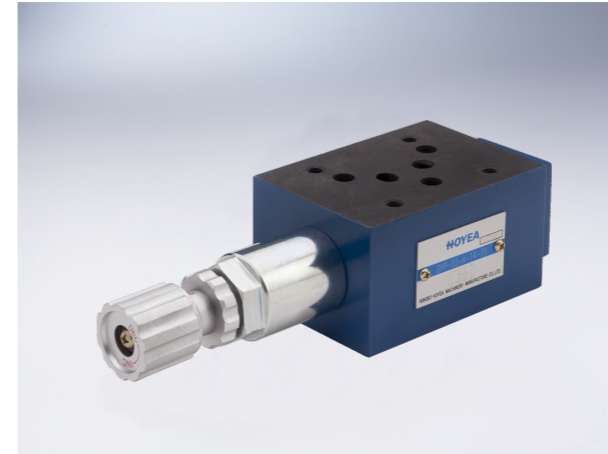

Specification	02	03
Max. working pressure (MPa)	31.5	
Max. Flow (L/min)	35	70
Working fluid	Mineral oil; phosphate-ester	
Fluid temp. (°C)	-20~70	
Viscosity (mm ² /s)	12~380	
Adjusting pressure (MPa)	7, 14,	21
Cleanliness	The maximum allowable cleanliness of the oil should be according to 9th degree of Standard NAS1638. It is suggested that the minimum filter rating should be β ₁₀ ≥ 75.	

B.8.1

Model description

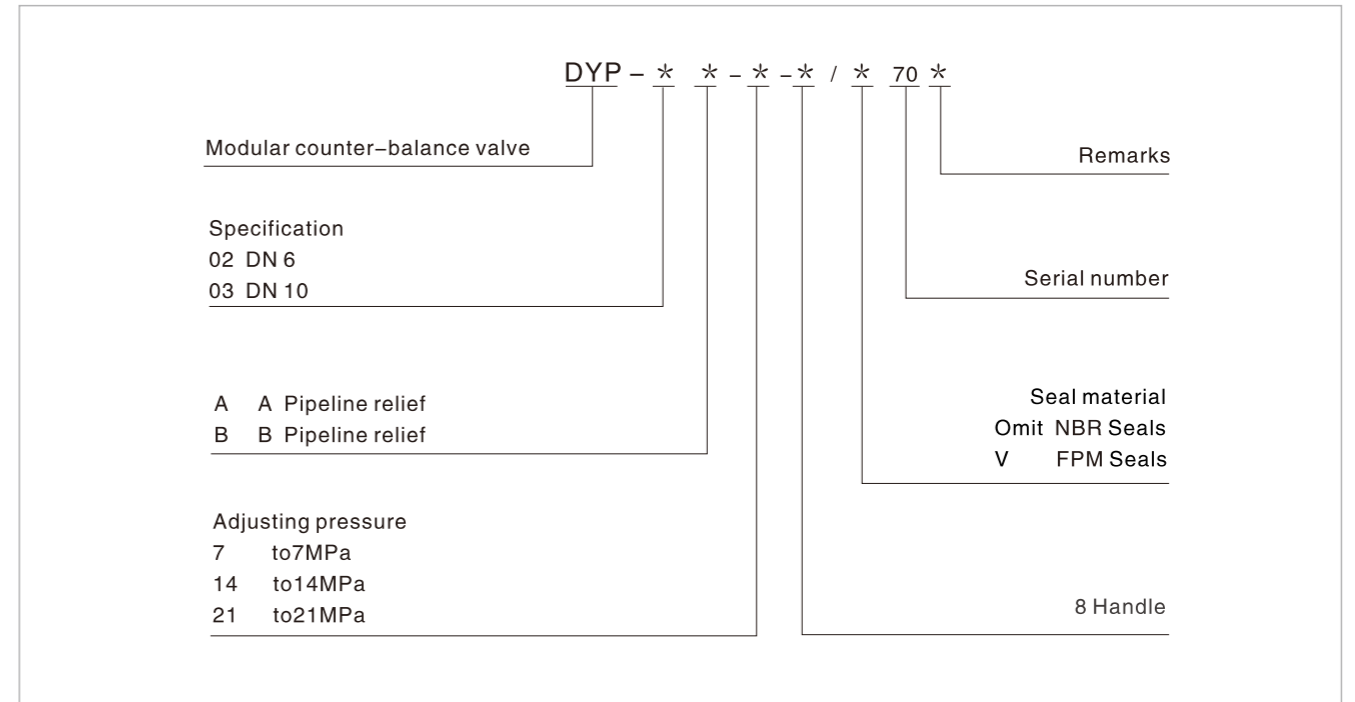

Code symbol

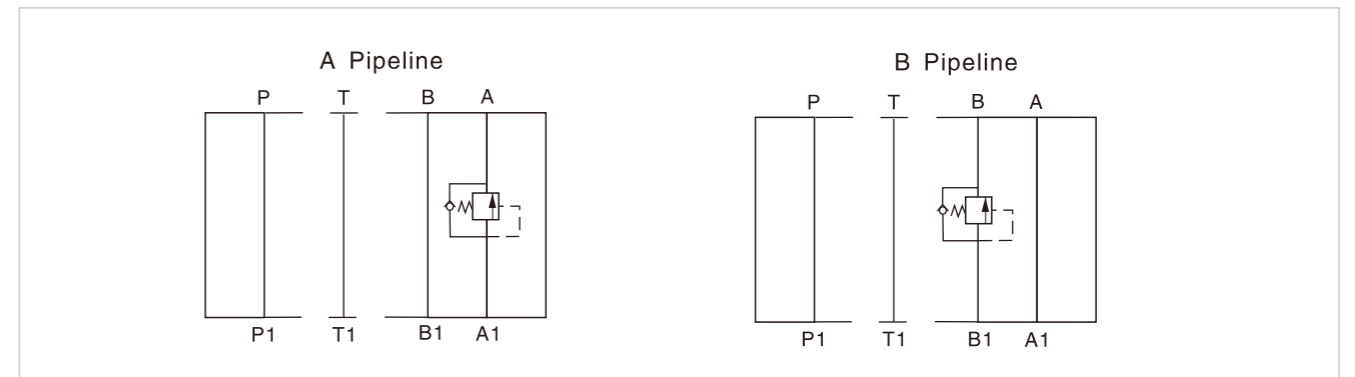

Modular Counter-balance Valve

02 External dimensions

DYP-02-A ...

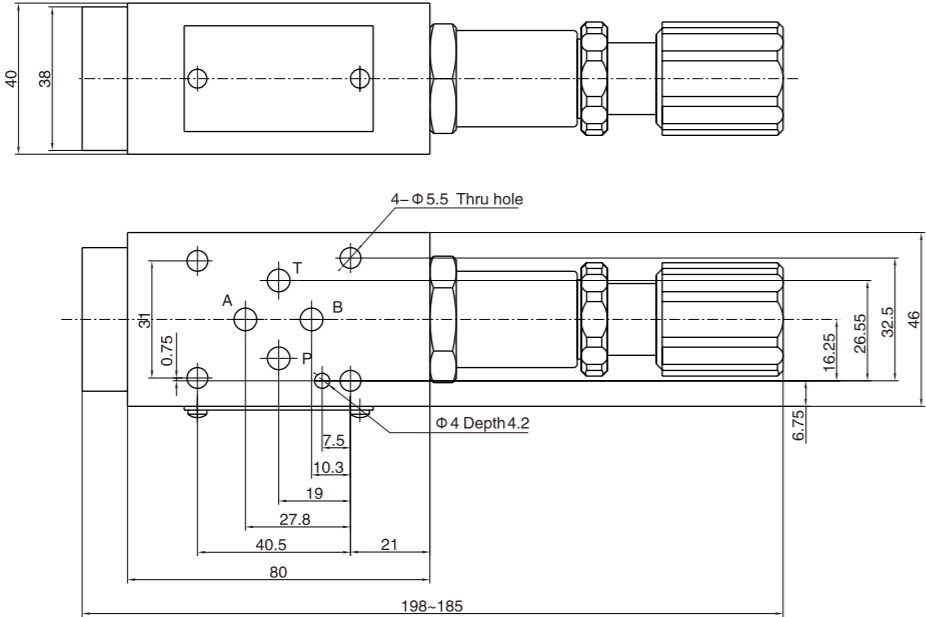

DYP-02-B ...

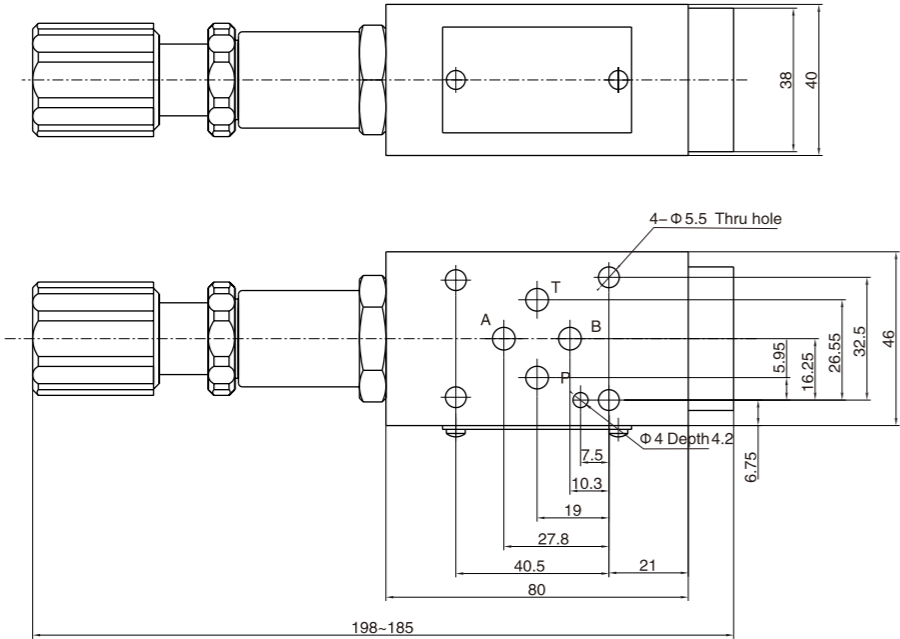

Modular Counter-balance Valve

03 External dimensions

DYP-03-A ...

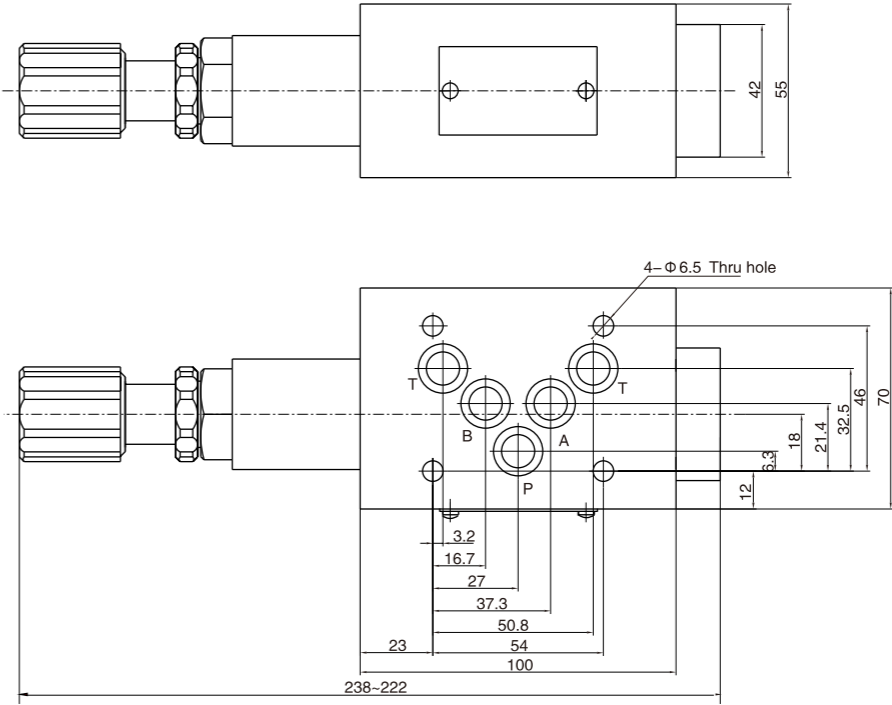

DYP-03-B ...

