

Dual Cross Relief Valves

Technical specification

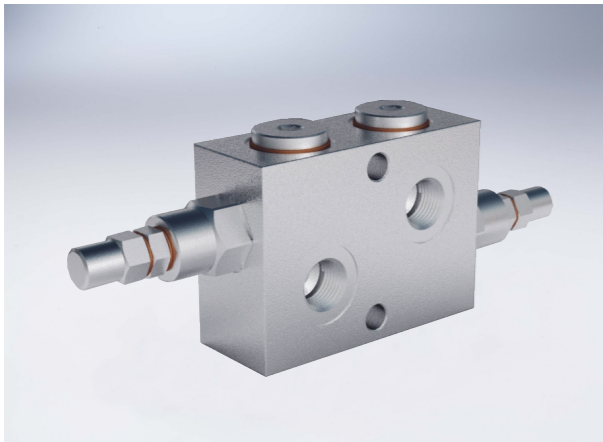

Specification		3/8"			1/2"	
Max.flow	(L/min)	45			70	
SPRINGS	Setting range(Bar)	10-50	20-100	10-180 Standard	50-250	80-300
	Pressure increase (Bar/turn)Q=4L/min	7	12	30	45	50
	Standard setting (Bar)	30	75	90	130	150

★For Setting less than 70Bar Q=12L/min

Use and operation:

Made up by 2 relief valves with crossed tank, this valve is used to block pressure to a certain setting in the 2 ports of an actuator/ hydraulic motor. It' s ideal to provide protection against sudden shock pressures and to adjust different pressures in the 2 ports of an hydraulic circuit as well. The 6 ports (2 ways in and 4 ways out reversible) enable to use just 1 valves for 2 cylinders.

Applications:

Connect V1 and V2 to the pressure flow or to the actuator/hydraulic motor. Vice versa for the remaining ports V1 and V2.Mounting by the actuator is highly recommended in order to avoid pressure drops.

Code symbol

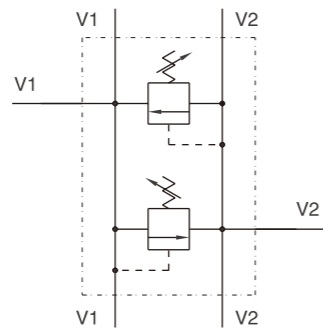

Pressure drops curve

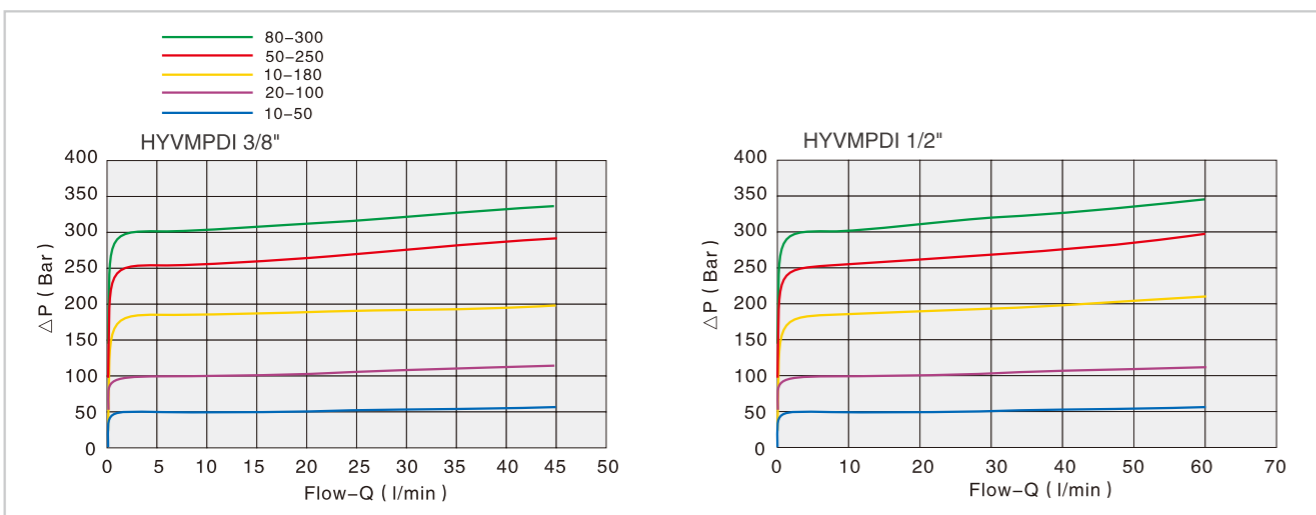

Dual Cross Relief Valves

External dimensions

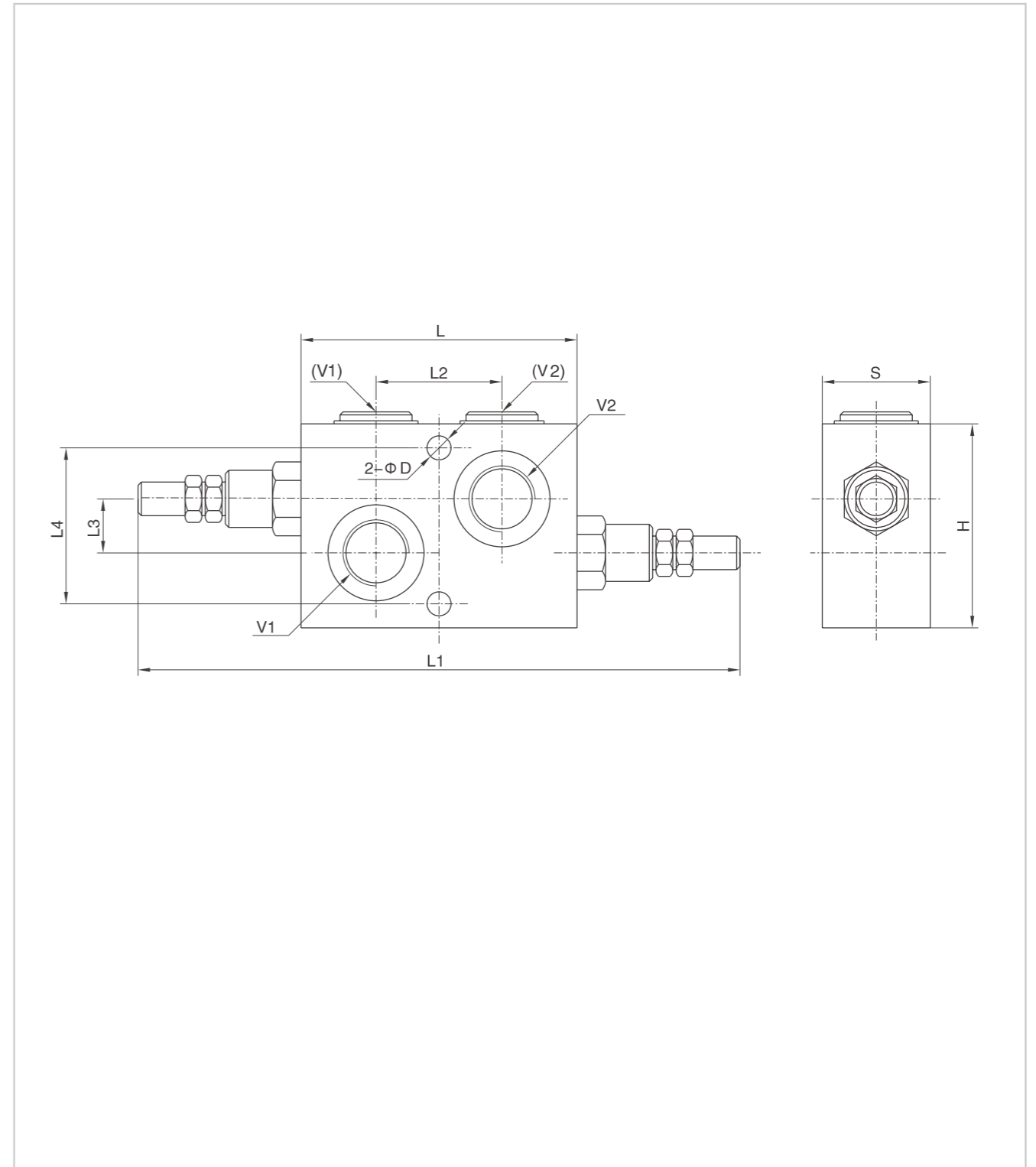

Type	V1/V2	L	L1	L2	L3	L4	D	H	S
HYVMPDI 3/8"	G 3/8"	90	215	42	18	50	8.5	66	35
HYVMPDI 1/2"	G 1/2"	90	215	42	18	50	8.5	66	35