

Explosion Isolation Solenoid Check Valve

External dimensions

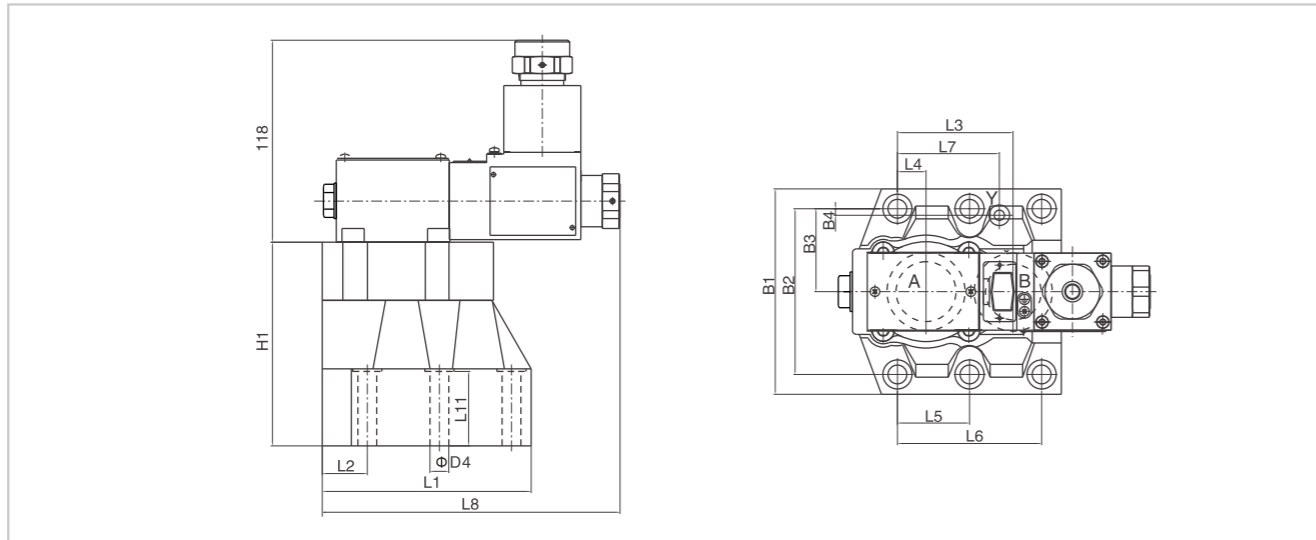

Specification	B1	B2	B3	B4	L1	L2	L3	L4	L5	L6	L7
GDAW-06	102	79.4	39.7	6.4	101	25	49.2	11.1	0	60.3	39.7
GDAW-10	120	96.8	48.4	3.8	122	26.3	67.5	16.7	42.1	84.2	59.5

Specification	L8	L9	L10	L11	L12	D1	D2	D3	D4	H1
GDAW-06	13.8	198	101	23	30	24	6	M10	11	95
GDAW-10	6.8	198	125	24	43.5	32	6	M10	11	119

Subplate size

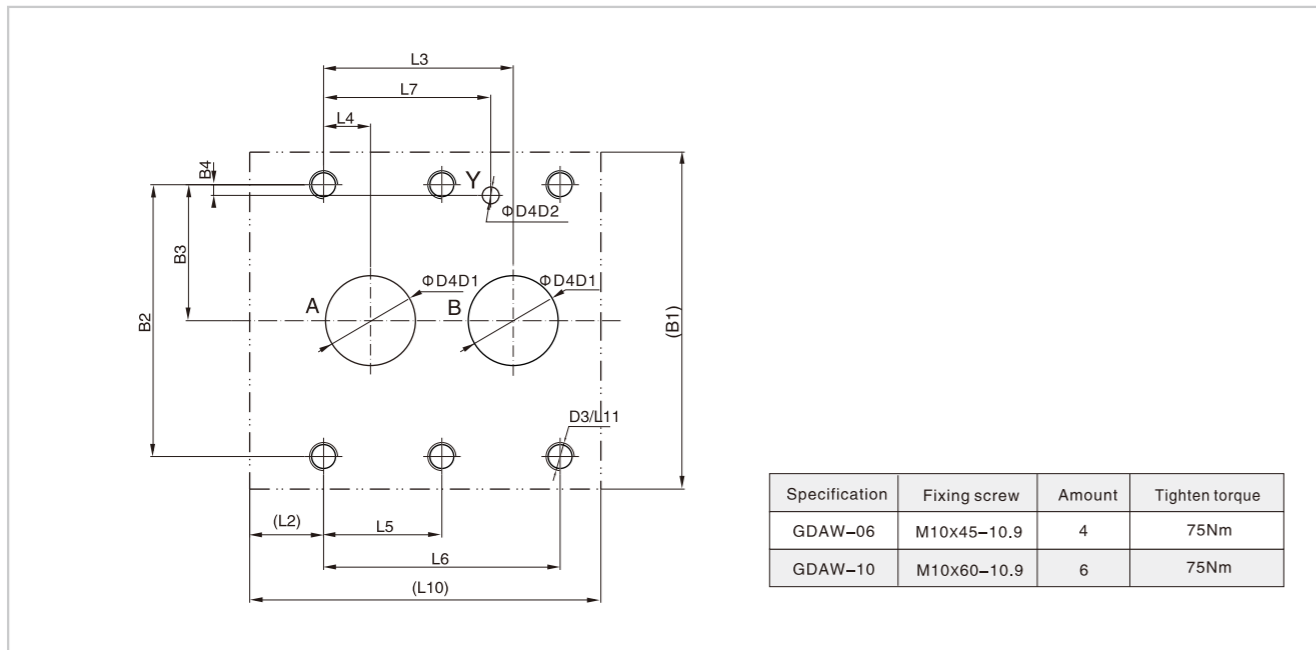

1. When installing the product, consider horizontal position firstly.
2. The medium used in the hydraulic system must be filtered. Its accuracy at least should be $20 \mu m$.
3. Screw should be according to the parameters of catalogue.
4. The surface, connecting with the valve, should be Ra0.8 roughness, and 0.01/100mm flatness.

Explosion Isolation Solenoid Directional Control Valve

Technical specification



Specification		02	03
Max. working pressure (MPa)	Oil ports P, A, B	31.5	
	Oil port T	10	
Max. Flow (L/min)		80	120
Working fluid		Mineral oil; phosphate-ester	
Fluid temp. (°C)		-20~70	
Viscosity (Mm ² /s)		2.8~380	
Working voltage (V)	DC	*AC	
	24	127	220
Cycle time (ms)	Open	25~45	10~20
	Close	10~25	15~40
Max. switch frequency (t/h)		15000	7200
Insulation grade		IP55	
Cleanliness	The maximum allowable cleanliness of the oil should be according to 9th degree of Standard NAS1638. It is suggested that the minimum filter rating should be $\beta_{10} \geq 75$.		

- 1) Working voltage is relative to the explosion-proof type, details please refer to "Product introduction".
- 2) For voltage AC, rectifier is integrated with the solenoid, no need for external rectifying.

Model instruction

GDFW - * - * - * * * / * * 52 *

Explosion isolation solenoid directional control valve		Remarks
Specification	02 DN 6 03 DN 10	Serial number
Function code	Details as following symbol table	Seal material Omit NBR Seals V FPM Seals
Working voltage	D24 DC24V B127 (AC127V Rectified) B220 (AC220V Rectified)	Omit No damping 08 $\Phi 0.8$ Damping 10 $\Phi 1.0$ Damping 12 $\Phi 1.2$ Damping
E	Ex d I Mb Ex d II C T6 Gb Ex d IIIC T80°C Db IP65	Omit without push rod emergency N9 with concealed push rod emergency

Notice: The corresponding relation between the working pressure and the types of explosion isolation is specified in the page of "Product Brief".

Explosion Isolation Solenoid Directional Control Valve

Code symbol

Spring return

3C2		2B2B		2B2BL	
3C3		2B3B		2B3BL	
3C4		2B4B		2B4BL	
3C5		2B5B		2B5BL	
3C6		2B6B		2B6BL	
3C7		2B7B		2B7BL	
3C9		2B9B		2B9BL	
3C10		2B10B		2B10BL	
3C11		2B11B		2B11BL	
3C12		2B12B		2B12BL	
3C25		2B25B		2B25BL	
3C29		2B29B		2B29BL	

Note: *D*(No spring return mechanical positioning)solenoid directional control valve should be installed horizontally

Name of solenoid

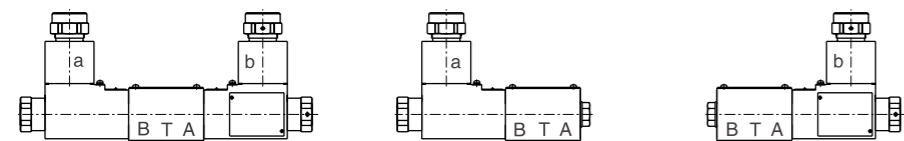

1. When movement a, P → A B → T
2. When movement b, P → B A → T
3. Oil flow in the opposite direction with the above-mentioned movement for 3C5、3C6、3C25

Explosion Isolation Solenoid Directional Control Valve

02 External dimensions

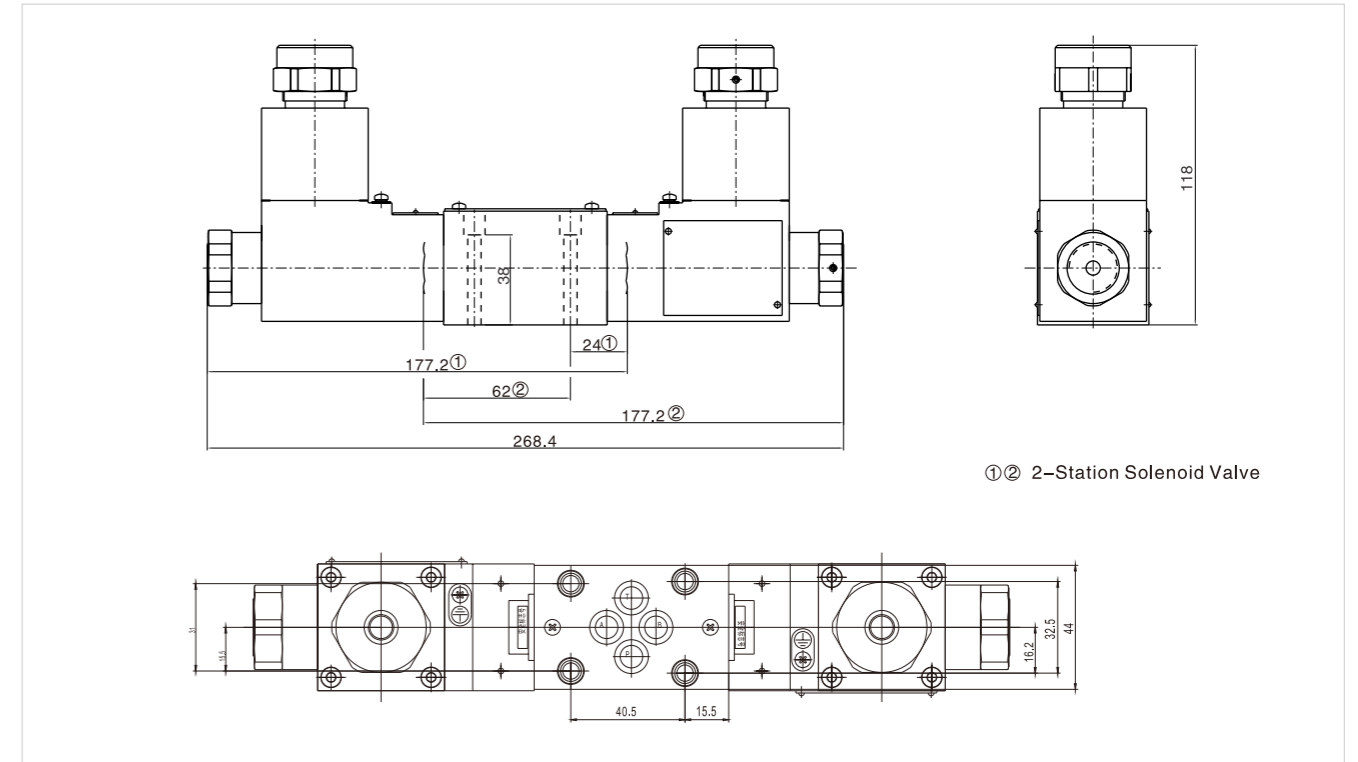

02 Subplate size

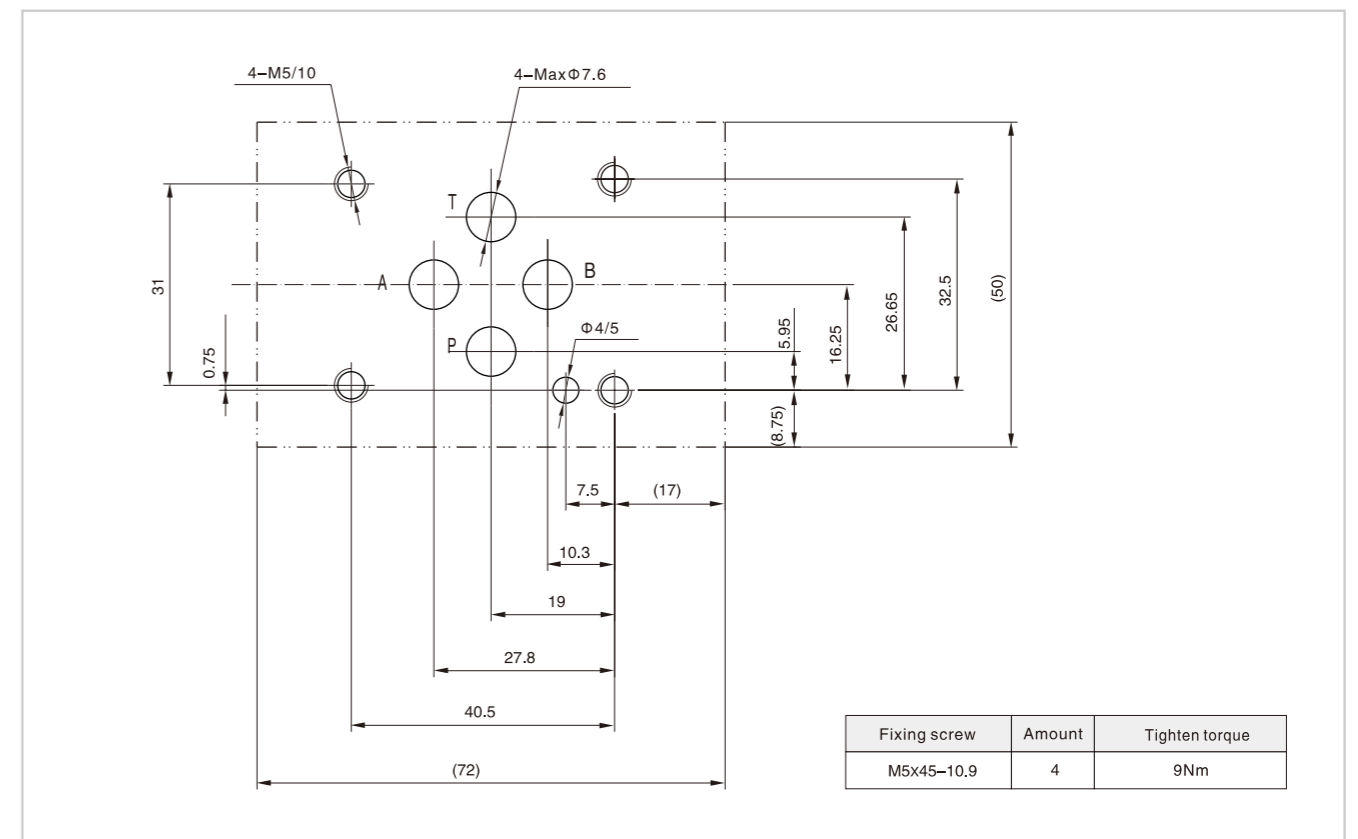

Explosion Isolation Solenoid Directional Control Valve

03 External dimensions

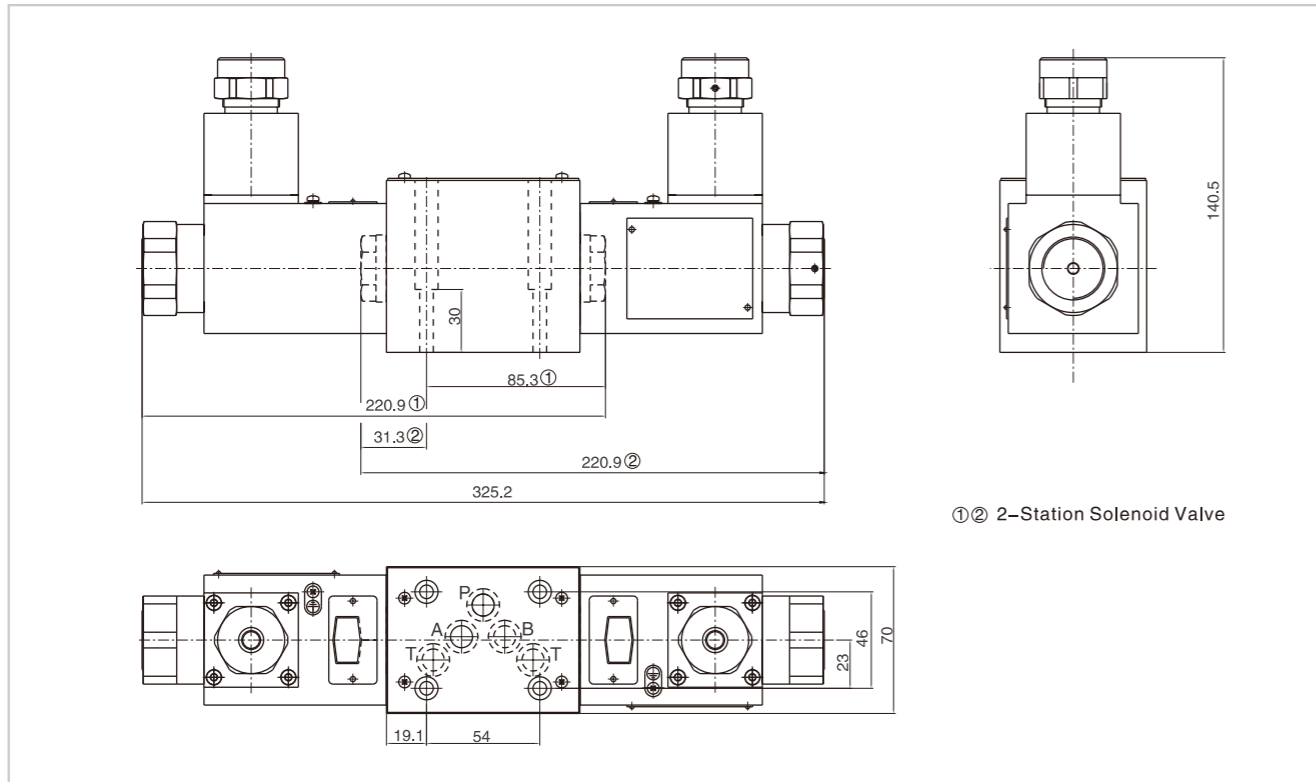

K.3.4

03 Subplate size

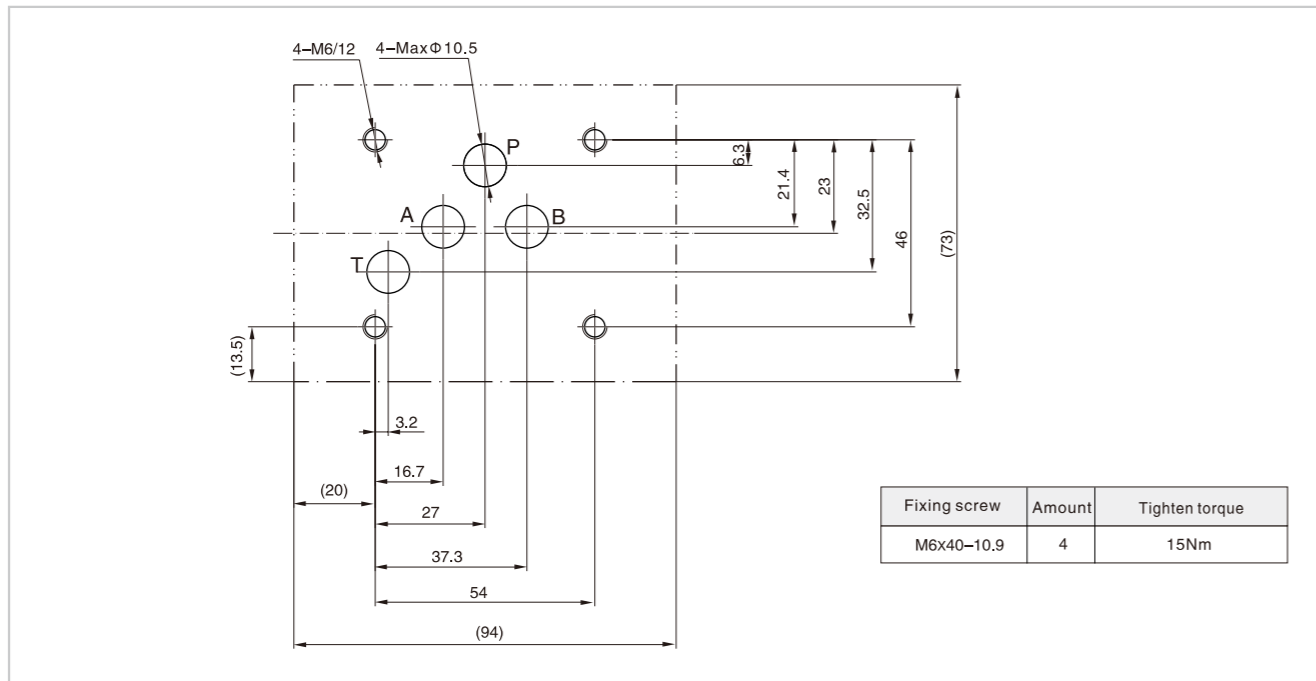

- When installing the product, consider horizontal position firstly.
- The medium used in the hydraulic system must be filtered, its accuracy at least should be 20 μm.
- Screw should be according to the parameters of catalogue.
- The surface, connecting with the valve, should be Ra0.8 roughness, and 0.01/100mm flatness.

Explosion Isolation Electro-hydraulic Directional Control Valve

Technical specification



- Working voltage is relative to the explosion-proof type, details please refer to "Product introduction".
- For voltage AC, rectifier is integrated with the solenoid, no need for external rectifying.

Specification		03		04		06		10		
		GDFWH	HGDFWH	GDFWH	HGDFWH	GDFWH	HGDFWH	GDFWH	HGDFWH	
Max. working pressure (MPa)	Oil ports	P, A, B		28	35	28	35	28	35	
	Oil port T	Pilot oil drain, Y external	10							
		Pilot oil drain, Y internal	25							
	Oil ports Y	10								
Max. Flow	(L/min)	160		300		650		1100		
Minimum control pressure (Mpa)	spring return	1.0		1.4		1.3		0.8		
	Hydraulic centration	-		1.4		1.8		0.8		
Max. working pressure (MPa)	25									
Working fluid	Mineral oil; phosphate-ester									
Fluid temp.	(°C)	-20~70								
Viscosity	(mm ² /s)	2.8~380								
Working voltage ¹⁾ (V)	DC	24								
	AC ²⁾	127/50Hz		220/50Hz						
Insulation grade	IP55									
Cleanliness	The maximum allowable cleanliness of the oil should be according to 9th degree of Standard NAS1638. It is suggested that the minimum filter rating should be β ₁₀ ≥ 75.									

K.4.1

Model instruction

* GDFWH - * * - * - * * * / * * * * * 52 *

Working pressure	Remarks
Omit 28MPa	Serial number
H 35MPa	Seal material
Explosion isolation electro-hydraulic directional control valve	Omit NBR Seals
Specification	V FPM Seals
02 DN6	Omit NO reducing valve
03 DN10	
06 DN25	
10 DN32	Omit ⁴⁾ NO prepressing valve
Main valve return type ³⁾	P4.5 With prepressing valve
Omit spring return	Omit No stroke adjusting device
H hydraulic centration	A end position valve with stroke adjustment
Function code, details as following symbol table	B of main valve with stroke adjustment
Working voltage	W Both heads with stroke adjustment
D24 DC24V	Omit No shifting time adjustment
B127 (AC127V Rectified)	With shifting time adjustment: Inlet flow control
B220 (AC220V Rectified)	With shifting time adjustment: Outlet flow control
Ex d I Mb	Omit No damping
Ex d II C T6 Gb	08 Φ0.8 Damping
E Ex d IIIC T80°C Db IP65	10 Φ1.0 Damping
Omit without push rod emergency	12 Φ1.2 Damping
N9 with concealed push rod emergency	Omit intl cntrl intl disch
	XY Extl cntrl extl disch
	X Extl cntrl intl disch
	Y Intl cntrl extl disch

3) Only spring return type available
4) The valve is used for central unloading electro-hydro directional valve of internal control, while not available for (H) GDFWH-03