

HYRV10-23 (Pilot Operated Relief Valve)

Description

A cartridge-style pilot-operated spool-type relief valve.

Operation

The valve prevents flow from ① to ② until pressure at ① exceeds the set crack pressure and opens the pilot section. The pilot flow creates a pressure differential across the spool which causes the valve to open allowing flow from ① to ② protecting the circuit from over pressurization. This cartridge relief valve offers a smooth transition in response to a load change in a hydraulic circuit.

Specifications

Operating pressure:	20.7-240 Bar
Flow:	7.6 ~ 113.6 Lpm (2 ~ 30 gpm)
Internal leakage:	0.5 ml/min. max. to 80% of nominal setting pressure
Reseat pressure:	90% Of crack pressure(crack pressure at 7.6 lpm /2 gpm)
Pressure rise:	At 240Bar (3500psi) : 0.15 bar/lpm (8 psi/gpm)
Temperature:	(-54°C To +135°C) with NBR material seals
Fluids:	Mineral-based fluids with viscosities of 7.4 to 420 cSt.
Cavity:	HY10-2,see page H.1.3
Body material:	Steel & ductile iron rated to 350 bar

Code symbol , profile and pressure drop vs.flow

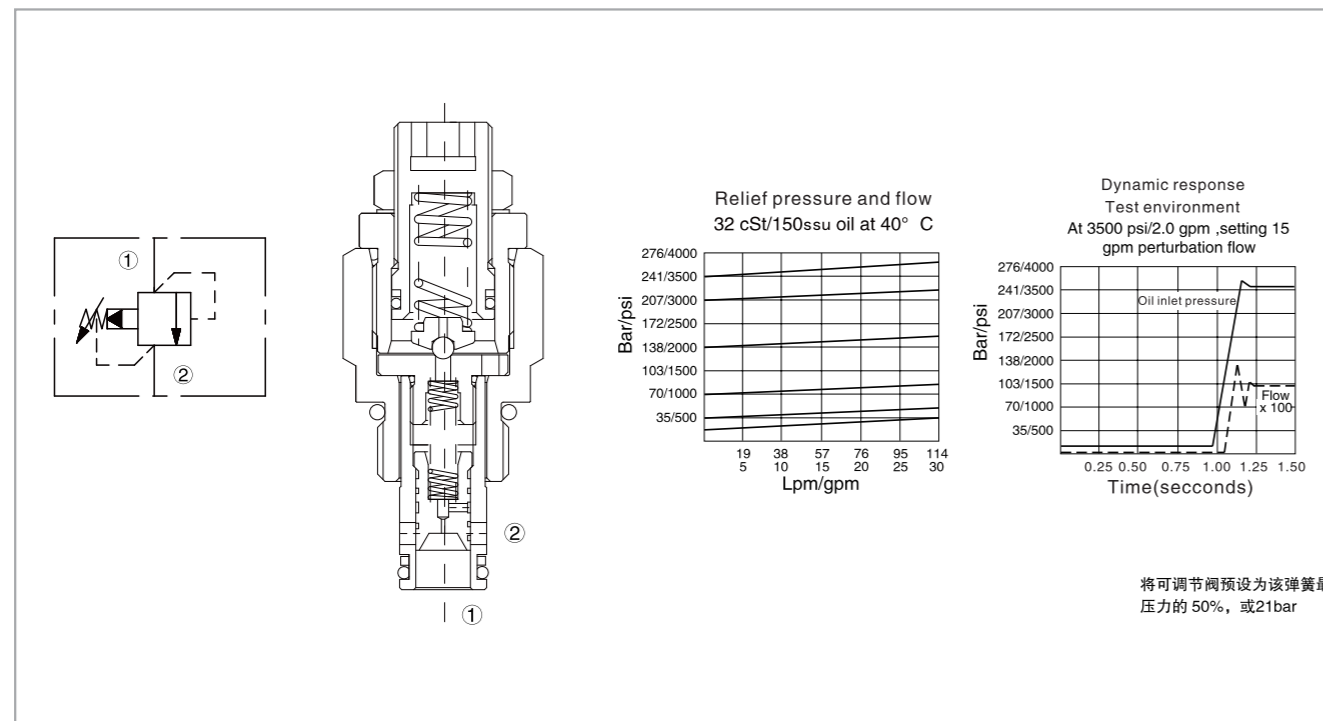

HYRV10-23 (Pilot Operated Relief Valve)

External dimensions

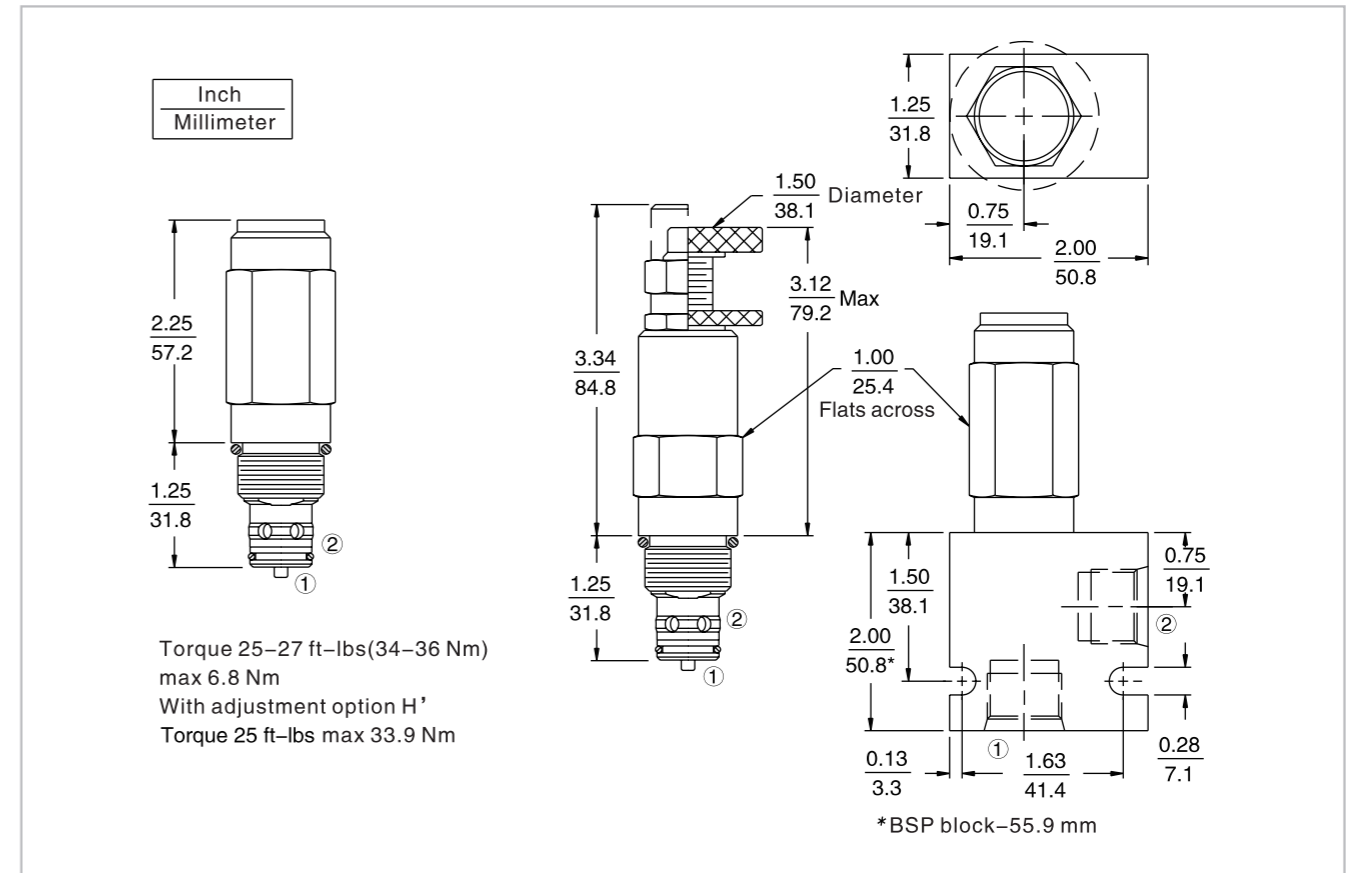

Material science and order model

Cartridge: weight: 0.25 kg (0.55 lb);
Steel, the working face is duratected
Surface zine-plated;
NBR material sealing and check ring (standard);
Aluminum knob with anodicoxidation.
Pressure over 240 bar (3500 psi), recommended use polyurethane material sealing and fluorocarbon material check ring;

Block: weight :0.16 kg (0.35 lb);
High-strength performance aluminum alloy with anodic oxidation;#6061 T6;
Rated pressure up to 240 bar (3500 psi);
See 8.010.1. Also available with ductile cast iron and steel material;
Size might be different, please consult factory.

